



# MG1<sup>®</sup>

## MAGNETIC SUPER-COMPACT SYSTEM FILTER

CT3070.0\_03  
EN  
July 2020



- Super compact
- Retains all impurities
- Fights corrosion
- Increases the lifespan of the boiler
- Maintains optimum system efficiency

Patent nr.  
102016000104280

### PRODUCTION RANGE

	Code	Size	Connection on system side	Connection on boiler side
	3070.05.00	G 3/4"	M UNI-EN-ISO 228 (ball valve)	F UNI-EN-ISO 228 (swivel connection)
	3070.05.50	G 3/4"	M UNI-EN-ISO 228 (ball valve)	F UNI-EN-ISO 228 (swivel connection)

### PRODUCTION RANGE - ACCESSORIES

	Code	Description	Size	Connection on boiler side
	3174.05.00	Straight rotary fitting, for filter/boiler connection.	G 3/4"	F UNI-EN-ISO 228 (swivel connection)
	3174.05.10	Curved rotary fitting, for filter/boiler connection.	G 3/4"	F UNI-EN-ISO 228 (swivel connection)
	3174.05.30	Flexible extendible fitting, for filter connection.	G 3/4"	M UNI-EN-ISO 228
	3174.05.20	Ball valve with rotary connection.	G 3/4"	M UNI-EN-ISO 228

### DESCRIPTION

**MG1** by **RBM** represents the best solution to solve plant problems due to particle pollution, especially sand and rust that are formed due to corrosion and scale during the normal operation of a system.

**OPERATING PRINCIPLE:** Through its effective and constant action, the magnetic filter collects all the impurities present in the system, preventing them from circulating within it, thus avoiding wear and damage of the rest of the components making up the system, circulators and heat exchangers in particular.

**MG1** performs as continuous protective action on the boiler.

**USE:** It is advised to install **MG1** on the return circuit, at the inlet of the boiler, in order to protect it from any impurities in the system, especially during the start-up phase.

Thanks to its compact dimensions, it can be installed under the boiler, in systems for domestic use, where installation spaces are very limited and there is no room for a traditional dirt separator.

**DEGREE OF FILTRATION:** **MG1** removes magnetic and non-magnetic particles that may cause damages to the system during the first day of operation.

The continuous passage of the fluid through the filter during the normal operation of the system on which it is installed, gradually removes any dirt.

**WARNINGS:** This filter contains powerful magnet, and strong magnetic fields are present within it.

We recommend the holders of pacemaker devices to keep at a safe distance during the filter operation and / or maintenance. Pay attention to the use of electronic equipment in the vicinity of the magnets, so as not to affect their operation.

## CONSTRUCTION FEATURES

- |  |  |
|--|--|
| <ul style="list-style-type: none"> <li>• Cartridge body:</li> <li>• Filter cap:</li> <li>• Filtering cartridge:</li> <li>• Hydraulic seals:</li> <li>• Magnet:</li> <li>• Ball valve body:</li> <li>• Swivel fitting:</li> </ul> | <p>Polyamide PA66 +30% FV<br/>                 Polyamide PA66 +30% FV<br/>                 AISI 304<br/>                 EPDM PEROX<br/>                 Neodymium REN35 B = 11.000 Gauss<br/> <math>B (MaxT) / B (RoomT) &lt; 1\%</math> (where MaxT = 130°C, RoomT = 21°C)<br/> <i>Tested according to IEC 60404-5 &amp; ASTM A977 regulations</i></p> <p>Brass<br/>                 Brass</p> |
|--|--|

## TECHNICAL FEATURES

- |   |   |
|---|---|
| <ul style="list-style-type: none"> <li>• Compatible fluid:</li> <li>• Max. operating pressure:</li> <li>• Operating temperature:</li> <li>• Degree of filtration:</li> <li>• Noise induced (according to EN13443 and UNI 3822)</li> </ul> | <p>Water, water + glycol<br/>                 3 Bar<br/>                 0÷90°C<br/>                 800 µm</p> |
|---|---|
- The noise induced by *MG1* in the piping is **0 dB(A)**.  
 As specified in EN 13443 regulation, *MG1* belongs to the **I group**, as well as all other products having noise levels < **20 dB(A)**.

## DIMENSIONAL FEATURES

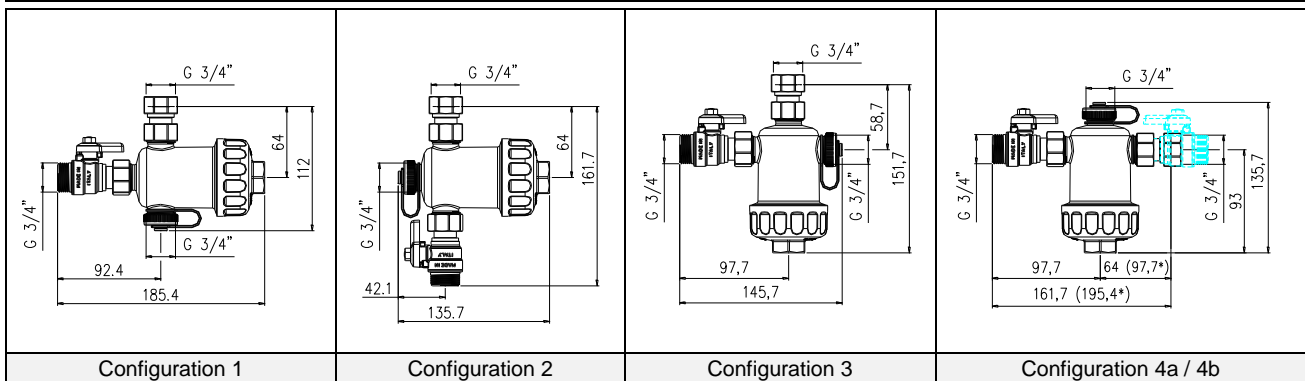

\* Value with accessory ball valve installed code 3174.05.20

## COMPONENTS DESCRIPTION

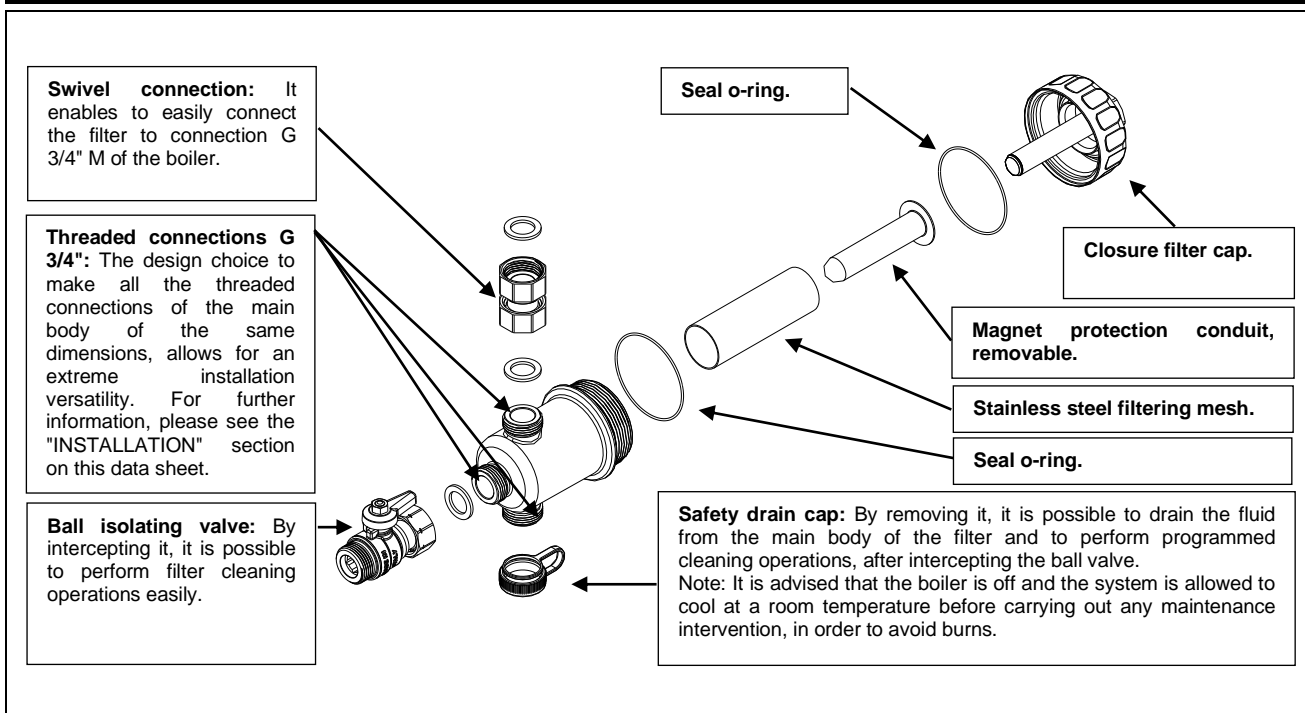

## FLUID DYNAMICS FEATURES

**Load losses diagram**

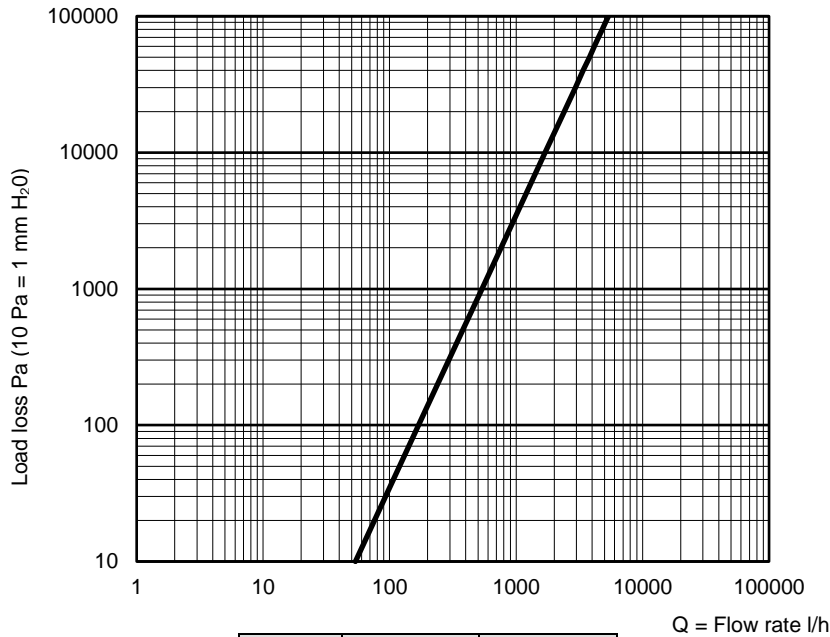

Size	Kv Angle (standard) [m <sup>3</sup> /h]	Kv Straight [m <sup>3</sup> /h]
G 3/4"	5.49	5.37

## OPERATING PRINCIPLE

By going through a set course, the fluid is forced to cross the mesh of the cartridge and enter the filtration chamber.

In the filtration chamber, thanks to the simultaneous action of:

- magnet
- filtering cartridge
- direction of the fluid given by the specific internal geometry

in the different phases, water is filtered from ferrous sludge.

First of all, the sudden cross-section variation (the filtering chamber has a greater diameter than the conduit) slows down the fluid motion and, consequently, the entrainment rate of the particles suspended in it, thus preventing them from avoiding the action exerted by the magnetic field.

The larger particles collide with the mesh of the filter cartridge and then slow down before circulating again.

The magnet, placed inside a cylinder at the centre of the filtration chamber, attracts all the impurities having magnetic characteristics.

In the filter installation configuration with the main cartridge/filter body facing downwards, the heavier particles fall downwards due to gravity, which prevails over the drag force.

**In this way, all magnetic (ferrous residues) and non-magnetic (algae, sludge, sand, etc.) contaminants in the system are retained in the filtration chamber.**

The stainless steel cartridge was developed in order not to exert excessive resistance to the passage of fluid (low load losses) and to favour a motion of the fluid itself that contributes to bring the heaviest particles to the bottom.

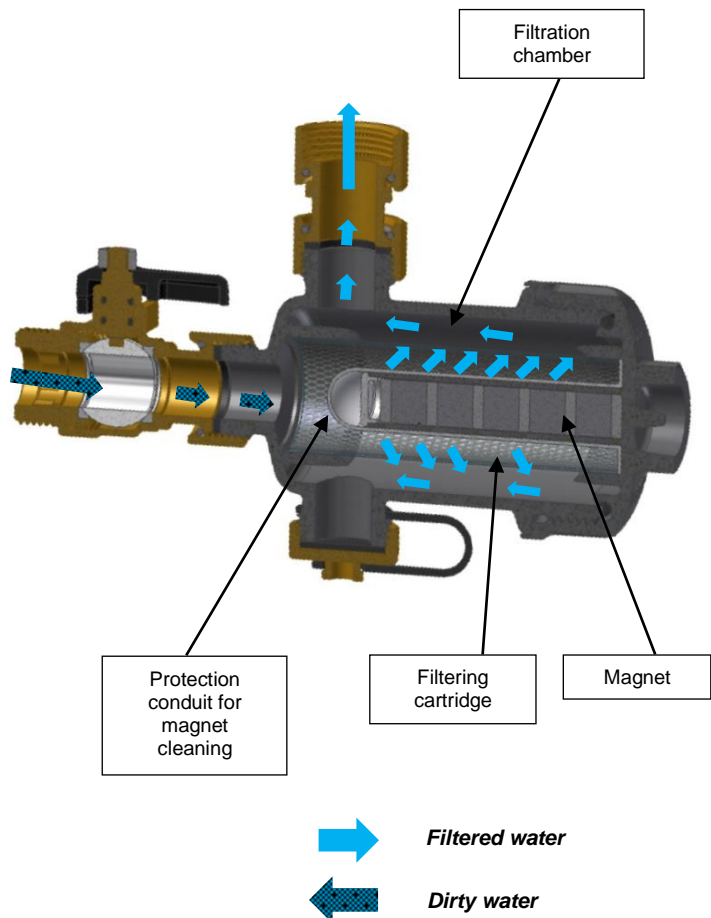

## INSTALLATION

It is advised to install *MG1* on the return circuit, at the inlet of the boiler, in order to protect it from any impurities in the system, especially during the start-up phase.

Thanks to a series of design solutions, *MG1* is characterised by an extreme installation versatility: it can be mounted either with the cartridge/filter body facing the front and downwards.

In case of limited space available under the boiler (e.g., boiler installed in kitchen cabinets), *MG1* must be installed with the main cartridge/filter body **facing the front**.

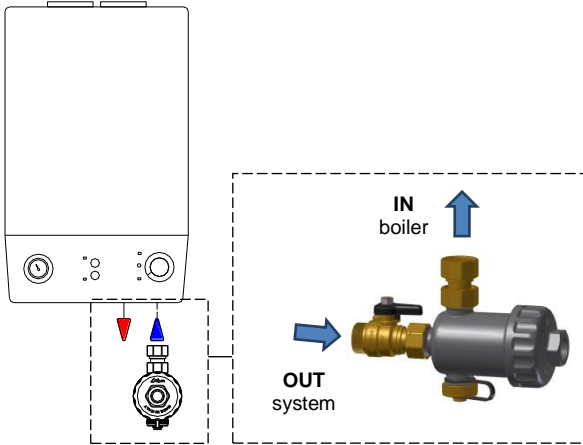

**Layout 1\*:**  
Application of *MG1* with the main cartridge/filter body **facing the front**.

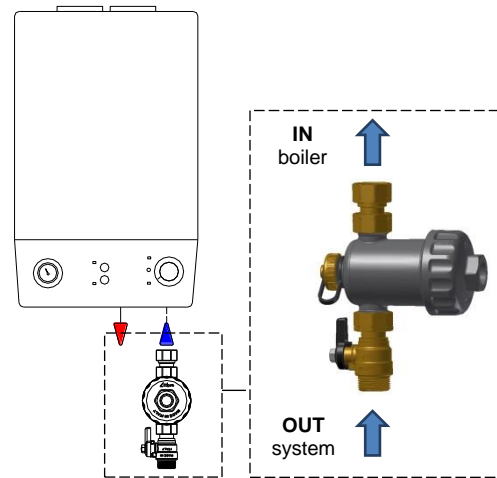

**Layout 2:**  
Application of *MG1* with the main cartridge/filter body **facing the front and with line connections**.

If there is more space available for installation, it is possible to position *MG1* with the main cartridge/magnet body **facing downwards**.

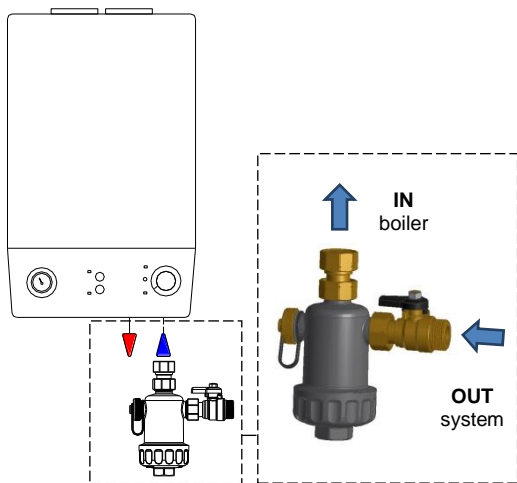

**Layout 3:**  
Application of *MG1* with the main cartridge/filter body **facing downwards**.

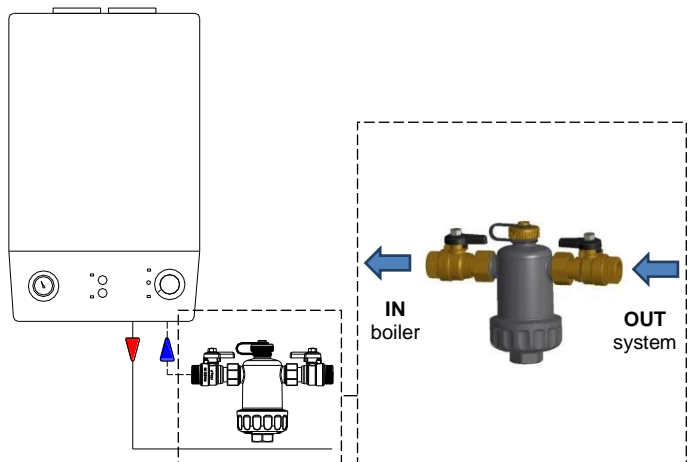

**Layout 4:**  
Application of *MG1* with the main cartridge/filter body **facing downwards** and with **line connections**. In order to comply with this installation, it is advised to provide for isolating valves on both filter connections (second ball valve available on request, code **3174.05.20**)

In order to allow the implementation of these installation configurations, it is sufficient to invert the position of the boiler connection swivel fitting and the ball valve (specifically in "Layout 2" and "Layout 4" also the drain cap) and rotate the filter by 90°.

This is possible because all the connections on the main body are made with the same thread G 3/4".

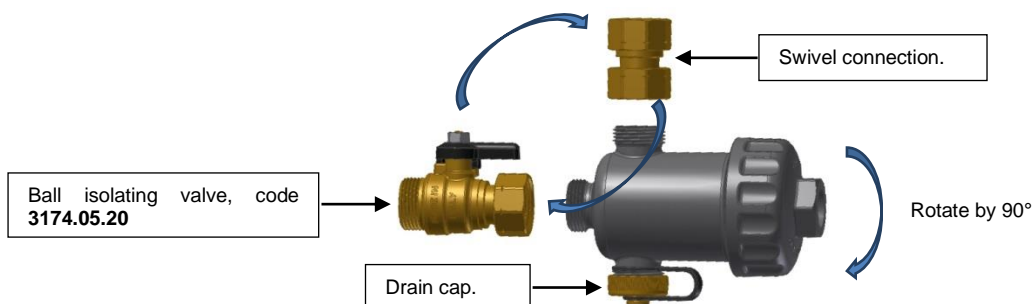

\* In **Layout 1**, in addition to magnetic filtering, *MG1* offers a high filtering capacity also for NON-magnetic particles.

## MAINTENANCE INTERVENTIONS

### **FILTERING CARTRIDGE CLEANING:**

It is possible to carry out cartridge periodical cleaning operations by unscrewing the lower drain cap or the closure filter cap.

Before cleaning *MG1*, ensure the working environment is safe.

RBM recommends that the boiler is off and the system is allowed to cool at a room temperature before carrying out any maintenance intervention, in order to avoid damages and burns.

Intercept the filter to be serviced by closing the ball valve(s).

Carefully unscrew the lower drain cap. Water will gradually drain (**Fig. 1 / Fig. 2**).

In case of filter vertical installation (**Fig. 3 and Fig. 4**), directly unscrew the filter cap with the help of a 29 mm wrench.

Ensure that water is collected in a container of suitable dimensions.

Once the water flow is interrupted, completely remove the cover/filter cap.

Extract the magnet protection conduit from the filter, so as to easily remove ferrous particles.

Wash with water and thoroughly rinse under the tap to completely remove any impurities.

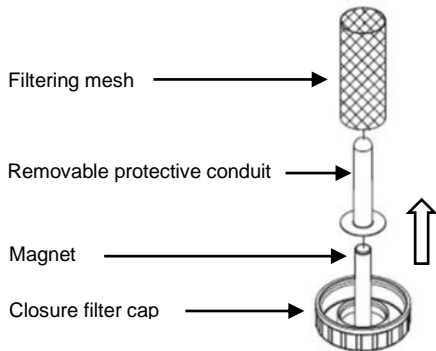

Ensure the O-ring seal is not damaged; if necessary, replace it.

Reassemble in reverse order.

Ensure there are no leaks prior to recommissioning.

In order to ensure a perfect hydraulic seal, and at the same time prevent damage to the components, in replacement of the filter observe the following tightening torques:

- Closure filter cap: tightening torque **10÷12 Nm**
- Lower drain cap: tightening torque **6÷7 Nm**

**N.B.:** In installation configurations shown in **Fig. 2** and **Fig. 4**, by intercepting both the ball valves and by relieving the pressure in the filter by means of the drain cap, it is possible to completely remove the filter to facilitate maintenance operations.

**It is important to perform the cleaning operation at least once a year. In case of first application, perform the first cleaning after a month.**

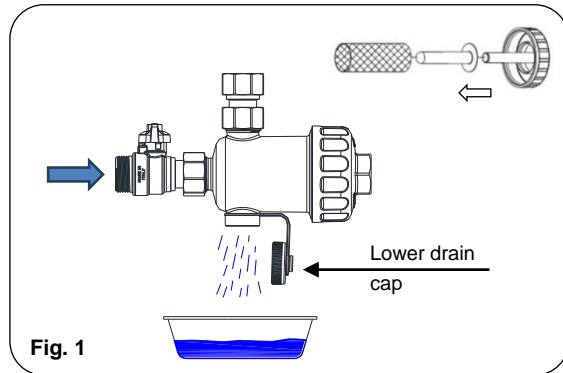

**Fig. 1**

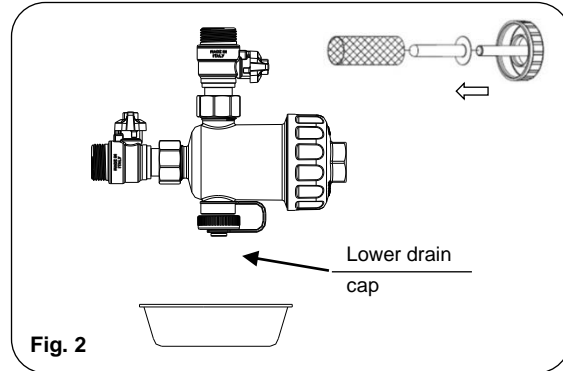

**Fig. 2**

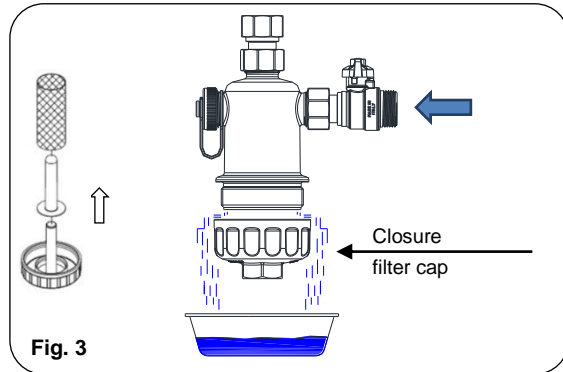

**Fig. 3**

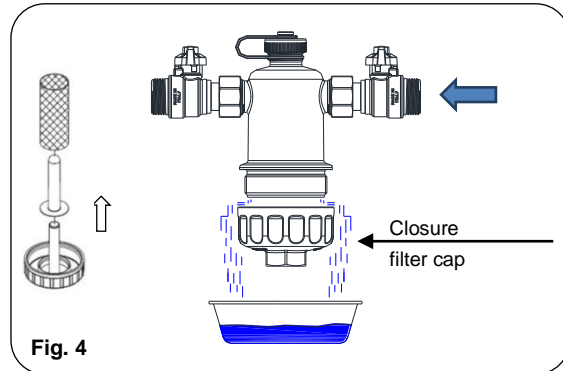

**Fig. 4**

## SPECIFICATION ITEMS

### **SERIES 3070**

Magnetic super compact system filter, model *MG1*. 3/4" M x 3/4" F threaded connection. Body in polymer. AISI 304 steel filtering cartridge. Seals in EPDM PEROX. Brass ball valve. Brass swivel fitting. Threaded connections MF UNI-EN-ISO 228.

Max operating pressure 3 Bar. Operating temperature 0÷90 °C. Neodymium magnet B = 11.000 gauss.  $B(\text{Max T}) / B(\text{Room T})^* < 1\%$  where \* Max T = 130 °C - Room T = 21 °C. Reduced dimensions; Retains all impurities; Excellent hydraulic properties; Increases the lifespan of the boiler; Fights corrosion; Maintains optimum system efficiency; Total passage isolating valves; Installation versatility.



RBM spa reserves the right to improve and change the described products and related technical data at any moment and without prior notice: always refer to the instructions attached with the supplied components; this sheet is an aid, should the instructions be extremely schematic. Our technical office is always at your disposal for any doubt, problem or explanation.



RBM Spa  
Via S. Giuseppe, 1  
25075 Nave (Brescia) Italy  
Tel. 030-2537211 Fax 030-2531798  
E-mail: info@rbm.eu - www.rbm.eu